

# MAGNITUDE™ 55H-FLD

55H-FLD • Flat Level Deck • Fixed tridem bogie lowbed

  
**FONTAINE®**  
HEAVY-HAUL

**Find out why more fleets  
and owner operators  
run with Fontaine® than  
ever before!**

## Fontaine Magnitude 55H-FLD Flat Level Deck Lowbed

- True 55 ton capacity in 12 feet  
(GAWR and tire ratings determine legal payloads)
- 25' clear deck length with 22" loaded height and 6" ground clearance  
(Optional deck lengths available)
- The most versatile hydraulic removable gooseneck in the industry
- 102" swing radius with connections for future 23" flip box (for 125" radius)
- Open bogie transition provides lowest load profile in the industry to reduce overall height
- Optional close coupled 4th axle or 14' 1" spreader to handle greater load capacities
- 5-position adjustable ride height for use with a wide range of fifth wheel heights

... and so much more. See your local Fontaine Heavy-Haul Dealer today and let's get to work!

[www.fontaineheavyhaul.com](http://www.fontaineheavyhaul.com) • 5398 US Highway 11 • Springville, AL 35146 • 205-467-6171

Weights shown are without options • Photos may show some optional equipment • Specifications subject to change without notice



# Fontaine Magnitude® 55H-FLD Specifications

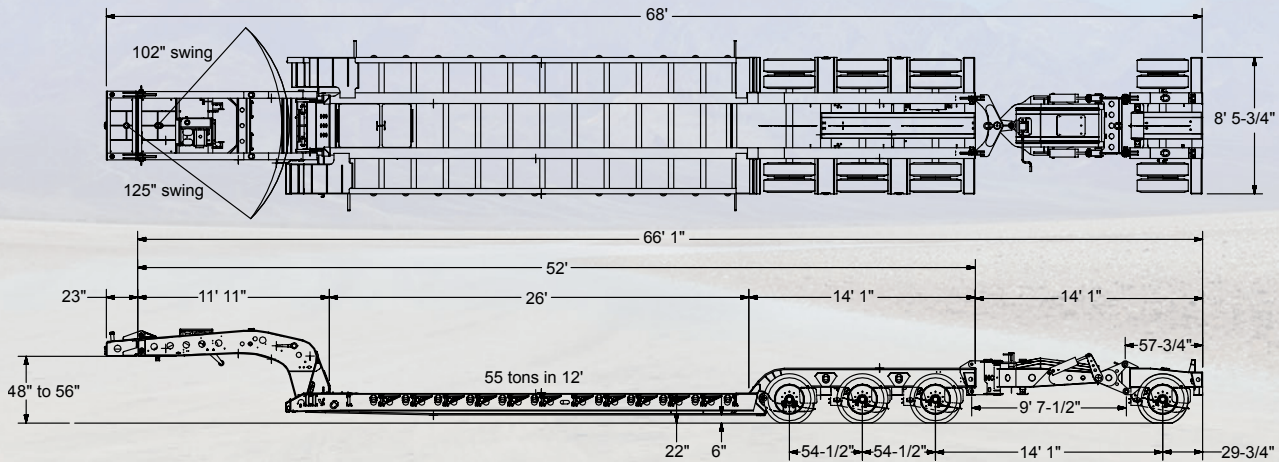

## MAIN BEAMS

- All main longitudinal members fabricated with 100 KSI minimum yield steel flanges with 50,000 lb webs

## CAPACITY

- 55 tons in 12' length with fourth axle close coupled or single axle spreader (GAWR and tire ratings determine legal payloads)

## LOAD BASE

- 12' rigid point load centered in deck

## DIMENSIONS

- Overall: 8' 6" width x 51' length (52' version shown above)
- Clear deck length: 25', flat level design (26' version shown above)
- Deck height under full load: 22" (ground clearance: 6")
- 50" nominal loaded fifth wheel height with 5 ride height positions
- Rear bogie height: 41"

## GOOSENECK

- Hydraulic, removable, non ground bearing, set up for wet line
- Adjustable ride height features 5-position mechanical lock for separate deck and fifth wheel height control
- 102" swing radius (11' 11" overall gooseneck length)
- Connections for future 23" flip box to achieve 125" swing radius
- J560 7-pin electrical connector

## DECK DESIGN

- Front of deck is sloped and features traction cleats to make loading and unloading easier
- Double outriggers at break over point
- 2" nominal apitong flooring (side rails only)
- Two forward mounted tool boxes with lockable covers
- Last three crossmembers in deck recessed
- 12 pair (24 total) removable swing-type extension brackets
- 2 pair (4 total) hook-on type extension brackets

## BOGIE DESIGN

- Fixed deck-to-bogie connection with front bogie ramp
- V-style boom trough with bolt-in pan
- Recessed load bearing bolsters between axles and behind last axle
- Air-lift 3rd axle extends tire life and improves fuel economy
- Mechanical ride height control valve
- Heavy-duty V-style rear bumper
- Connections for future axle/spreader including air and electrical connections

## AXLES

- 3 heavy-duty axles with 54 1/2" spread (60" spread optional)
- Close coupled 4th axle or 14' 1" spreader options available
- 25,000 lbs nominal capacity per axle (GAWR determined by suspension type, brakes, tires and other components)
- Tapered spindle axles, automatic slack adjusters and drum brakes
- 1 set of mudflaps

## BRAKES

- 16 1/2" x 7" with 5 1/2" autoslacks (3 axles)
- Heavy-duty brake drums, outboard mount
- Quick change replacement feature saves repair time
- Automatic slack adjusters maintain positive braking action

## HUBS

- Hub-piloted 10-stud mount for increased capacity and durability
- Outboard cast drums save time and cost on brake repairs

## WHEELS/TIRES

- 8.25 x 22.5 steel disc wheels with 275/70R 22.5 H-ply tires

## SUSPENSION

- Unitized air-ride suspension with automatic and manual controls
- Suspension mount is engineered, reinforced and braced to virtually eliminate frame cracking

## ELECTRICAL SYSTEM

- Sealed harness for maximum corrosion resistance
- DOT sealed beam and harness with LED lights and 4" LED beacon strobe—flush mounted with battery power supply
- Marker lights and mid-turn signals
- 3 stop, tail and turn lights per side on rear

## PROTECTIVE COATING

- Highest quality 2-part polyurethane enamel fights corrosion to extend the life of your trailer
  - Shot blasted and cleaned prior to painting
  - Primed for better paint adhesion

## LASH RINGS

- 14 pair (28 total), bent D-Ring design ensures longer chain life and better payload securement

## FLAG HOLDERS

- 2 pair (4 total)

## ESTIMATED EMPTY WEIGHT

W/O OPTIONS: 21,640 lbs ± 3%

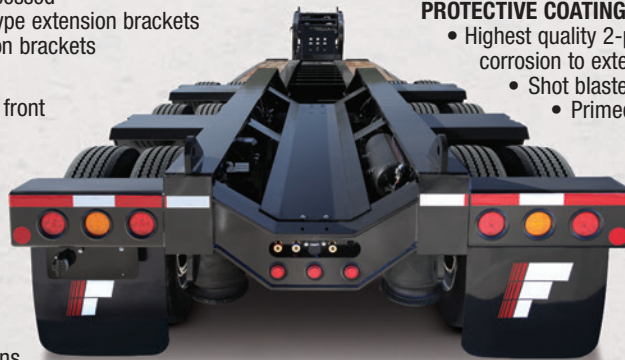

Specifications subject to change without notice.  
Photos show some optional equipment.



www.fontaineheavyhaul.com • 5398 US Highway 11 • Springville, AL 35146 • 205-467-6171

Weights shown are without options • Photos may show some optional equipment • Specifications subject to change without notice